

2/2-way proportional valve



- High sensitivity
- 0 to 25 bar
- DN 2 to 8 mm
- G 3/8 and G 1/2

Type 2835 can be combined with...



Type 8605

Digital control electronics
Cable plug version



Type 8605

Digital control electronics
DIN-rail version



Type 2508

Cable plug



Type 8611

Universal controller

The direct-acting proportional valve Type 2835 can be used as a control valve for process control and is suitable for technical vacuum. Low hysteresis, high repeatability and high sensitivity ensure superior regulation behaviour. Thanks to an elastomeric sealing, the valve closes tightly and securely.

Circuit function A

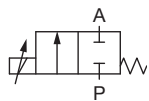

Direct acting 2-way
proportional valve,
normally closed

Valve control takes place through the control electronics of Type 8605, which converts an analogue input signal into a PWM signal¹⁾.

Further, functional features of the Type 8605 electronic control unit:

- Temperature compensation for coil heating by internal current regulation
- Simple zero and span settings
- Ramp function to dampen fast status changes

Technical Data - valve	
Body material	Brass, Stainless steel
Seal material	FKM, EPDM on request
Media	Neutral gases, liquids
Medium temperature	-10 ... +90 °C
Ambient temperature	max. +55 °C
Viscosity	max. 21 mm ² /s
Operating voltage	24 V DC
Power consumption	16 W
Duty cycle	100 % continuously rated
Port connection	G 3/8, G 1/2, NPT 3/8, NPT 1/2
Electric connection	Cable plug (DIN EN 175301-803 Form A)
Installation	As required, preferably with actuator in upright position
Typical control data²⁾	
Hysteresis	< 5 %
Repeatability	< 0,25 % of F.S.
Sensitivity	< 0,25 % of F.S.
Turn-down ratio	1:100
Protection class - valve	IP65

¹⁾ PWM pulse-width modulation

²⁾ Characteristic data of control behaviour depends on process conditions

Dimensions [mm]

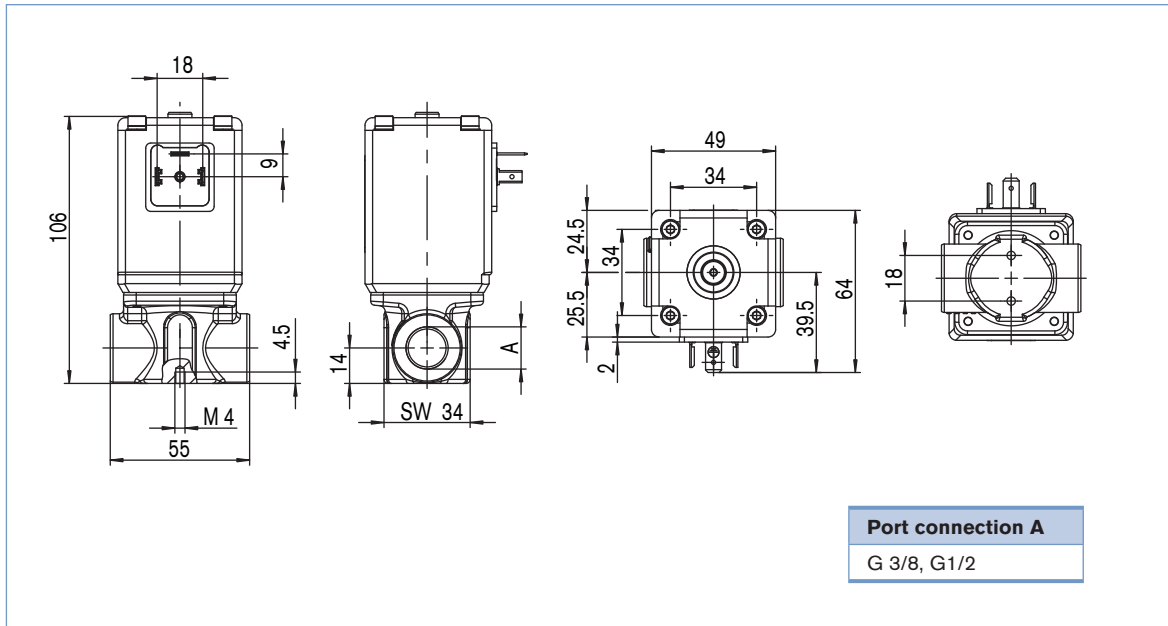

Characteristics of a proportional valve

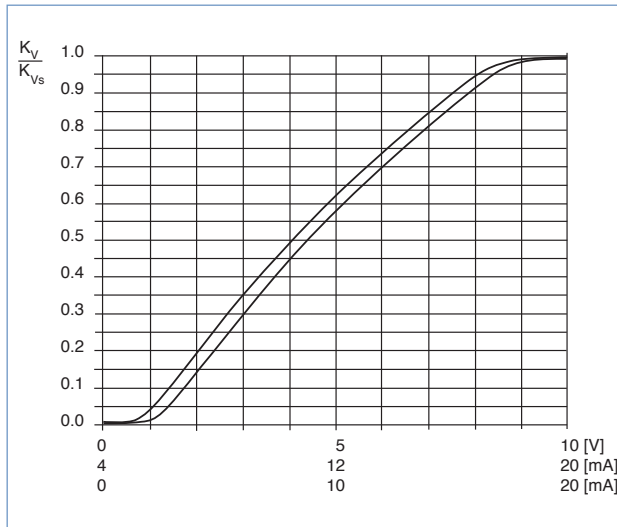

Advice for valve sizing

In continuous flow applications, the choice of appropriate valve size is much more important than with on/off valves. The optimum size should be selected such that the resulting flow in the system is not unnecessarily reduced by the valve. However, a sufficient part of the pressure drop should be taken across the valve even when it is fully opened.

recommended value: $\Delta p_{\text{valve}} > 30\%$ of total pressure drop within the system

For that reason take advantage of Bürkert competent engineering services during the planning phase!

Determination of the kv value

Pressure drop	kv value for liquids [m³/h]	kv value for gases [m³/h]
Subcritical $p_2 > \frac{p_1}{2}$	$= Q \sqrt{\frac{\rho}{1000 \Delta p}}$	$= \frac{Q_N}{514} \sqrt{\frac{T_1 \rho_N}{p_2 \Delta p}}$
Supercritical $p_2 < \frac{p_1}{2}$	$= Q \sqrt{\frac{\rho}{1000 \Delta p}}$	$= \frac{Q_N}{257 p_1} \sqrt{T_1 \rho_N}$

- k_v Flow coefficient [m³/h] ¹⁾
- Q_N Standard flow rate [m_N³/h] ²⁾
- p_1 Inlet pressure [bar] ³⁾
- p_2 Outlet pressure [bar] ³⁾
- Δp Differential pressure $p_1 - p_2$ [bar]
- ρ Density [kg/m³]
- ρ_N Standard density [kg/m³]
- T_1 Temperature if fluid medium [(273+t)K]

- ¹⁾ measured for water, $\Delta p = 1$ bar, via the device
- ²⁾ Standard conditions at 1.013 bar³⁾ and 0 °C (273K)
- ³⁾ Absolute pressure

Ordering chart for valves

All valves with FKM sealing

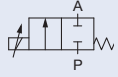
Circuit function	Orifice [mm]	Port connection	k_v value water [m ³ /h] ¹⁾	Q_{Nn} value [l/min] ²⁾	Maximum pressure [bar] ³⁾	Coil power consumption [W]	Maximum coil current [mA]	Item no. Brass body	Item no. Stainless steel body
A 2/2-way normally closed (NC) 	2 ⁴⁾	G 3/8	0.12	129	25	16	750	175 980	175 996
		NPT 3/8	0.12	129	25	16	750	175 997	175 998
	3	G 3/8	0.25	270	10	16	750	175 999	176 000
		NPT 3/8	0.25	270	10	16	750	176 001	176 002
	4	G 3/8	0.45	485	8	16	750	176 003	176 004
		NPT 3/8	0.45	485	8	16	750	175 995	175 984
		G 1/2	0.45	485	8	16	750	176 005	176 006
	6	NPT 1/2	0.45	485	8	16	750	175 985	175 986
		G 1/2	0.80	862	4	16	750	175 989	175 990
	8	NPT 1/2	0.80	862	4	16	750	175 993	175 994
		G 1/2	1.10	1186	2	16	750	178 794	179 412
			NPT 1/2	1.10	1186	2	16	750	179 305

¹⁾ k_v s value: Flow rate value for water, measured at +20 °C and 1 bar pressure differential over a fully opened valve.

²⁾ Q_{Nn} value: Flow rate value for air with inlet pressure of 6 bar¹⁾, 1 bar pressure differential and +20 °C.

³⁾ Pressure data [bar]: Overpressure with respect to atmospheric pressure

⁴⁾ for $\Delta p > 10$ bar it is possible to get discontinuities in the characteristic curve because of flow conditions in the application

Please note that the valves are delivered without control electronics unit and cable plug (see accessories below).

Further versions on request

 **Materials**
Seal: FFKM (resistant to aggressive media), EPDM

 **Analytical**
Oxygen version
Part oil-, fat- and silicon free

 **Electrical connection**
12 V coil

 **Approvals**
UL recognised, CSA

Ordering chart for accessories

Cable plug Type 2508 according to DIN EN 175301-803 Form A

The delivery of a cable plug includes the flat seal and fixing screw

Circuitry	Voltage / frequency	Item no.
None	0 - 250 V AC/DC	008 376
None, with 3 m cable	0 - 250 V AC/DC	783 573

Electronic Control Type 8605

Please see Datasheet

Note
You can fill out the fields directly in the PDF file before printing out the form.

Design data for proportional valves

▶ Please fill out this form and send to your local Bürkert Sales Centre* with your inquiry or order

Company	Contact person
Customer no.	Dept.
Address	Tel./Fax
Town / Postcode	E-Mail

= Mandatory fields Quantity Desired delivery date

Process data

Medium

State of medium liquid gaseous vaporous

Medium temperature °C

Maximum flow rate $Q_{nom} =$ Unit:

Minimum flow rate $Q_{min} =$ Unit:

Inlet pressure at nominal operation $p_1 =$ barg

Outlet pressure at nominal operation $p_2 =$ barg

Maximum inlet pressure $p_{1max} =$ barg

Ambient temperature °C

Additional specifications

Body material Brass Stainless steel

Seal material FKM other

Note Please state all pressure values as **overpressures with** respect to atmospheric [barg].

To find your nearest Bürkert facility, click on the orange box →

www.burkert.com

In case of special application conditions, please consult for advice

Subject to alterations
© Christian Bürkert GmbH & Co. KG

0905/5_EU-en_00891984